

CITY COUNCIL MEETING AGENDA
Monday, March 24th, 2025, 7:00 PM
Eldridge Community Center · 400 S 16th Ave · Eldridge, IA

1. Call to Order and Roll Call
2. Pledge of Allegiance
3. Approval of Agenda
4. Proclamation for “Junior Achievement Day”
5. Public Comment

6. Mayor’s Agenda
 - A. Consideration to Approve City Council Minutes from March 3rd, 2025
 - B. Consideration to Approve Committee of the Whole Minutes from March 3rd, 2025
 - C. Consideration to Approve Bills Payable
 - D. Consideration to approve Board/Committee Re-Appointments for:
 1. Karl Donabauer to the Board of Adjustment for a term expiring 03/19/2030
 2. Paul Hayungs to the Board of Adjustment for a term expiring 03/19/2025
 3. Nathan Kessler to the Economic Development Committee for a term expiring 4/4/2028
 4. Mitch Cunningham to the Economic Development Committee for a term expiring 4/4/2028
 5. Patrick Reid to the Economic Development Committee for a term expiring 4/4/2028
 6. Lacey Daedlow to the Economic Development Committee for a term expiring 4/4/2028
 7. Steve Fahrenkrog to the Economic Development Committee for a term expiring 4/4/2028
 8. Joe Stutting to the Economic Development Committee for a term expiring 4/4/2028

7. Old Business
 - A. Consideration of Third & Final Reading of Ordinance #2025-07 Updating the City Sanitary Sewer Rates
 - B. Consideration of Second Reading of Ordinance #2025-05 Shared Use Paths
 - C. Consideration of Second Reading of Ordinance #2025-08 Updating Deduct Meter Policy

8. New Business
 - A. Consideration of First Reading of Ordinance #2025-09 Amending Section 8, Chapter 2, Title C of the Eldridge City Code to require 5’ public sidewalks in new developments
 - B. Consideration to approve a resident request to donate a memorial bench and plaque and to authorize the donated bench to replace an existing bench located along LeClaire Road in front of the City maintenance shop
 - C. Consideration to approve quote from Precision Concepts in the amount of \$3,082.37 to install Reflective Mirror and Retention Film on City Hall windows
 - D. Consideration of Resolution #2025-09 Approving FY25 Budgeted Interfund Transfers

9. Board/Staff Activity Reports
 - A. City Administrator
 - B. Assistant City Administrator
 - C. City Clerk
 - D. Police Chief

10. Closed Session pursuant to Iowa Code 21.5(1)c “To discuss strategy with counsel in matters that are presently in litigation or where litigation is imminent where its disclosure would be likely to prejudice or disadvantage the position of the governmental body in that litigation.”

11. Adjournment

Next Special City Council Meeting: Monday, April 7th, 2025, at 5:30pm at Eldridge Community Center

Next Regular Committee of the Whole & City Council Meeting: Monday, April 7th, 2025, at 6:00pm at Eldridge Community Center

City of Eldridge

Mayor Frank King

PROCLAMATION

WHEREAS, the City of Eldridge will observe Junior Achievement Day on the first Thursday in April, as an opportunity to recognize and celebrate Junior Achievement of the Heartland for empowering our young people to own their economic success.

WHEREAS, Junior Achievement of the Heartland's educational contribution equips our young people to become the next generation of productive employees and self-sufficient citizens to ensure the economic prosperity of Eldridge.

WHEREAS, it is fitting for parents, educators, businesses and other members of the community to join in Junior Achievement's effort to ensure the future success and economic health of our young people and the communities in which they live.

NOW, THEREFORE, I, Frank King, Mayor of Eldridge, do hereby proclaim official recognition of April 3, 2025 and every first Thursday of April hereafter as

Junior Achievement Day
in the City of Eldridge

City of Eldridge City Council Meeting Minutes

The City of Eldridge, Iowa, City Council met in an open session at Eldridge Community Center at 7:09 pm on March 3, 2025.

Council Members Present: Dan Collins, Brian Dockery, Scott Campbell, and Ryan Iossi. Not Present: Adrian Blackwell. Quorum was met.

Presiding: Mayor Frank King.

Also Present: Nevada Lemke, Jeff Martens, Letty Goslowsky, Erin Gentz, Dale Grunwald, Marty O'Boyle, Ray Nees, Scott LaPlant, Kalen Gromet and Karsyn Allen.

Motion by Campbell to approve the agenda. Second by Iossi Motion was approved unanimously by voice vote.

Public Comment None.

Mayor's Agenda

Motion by Campbell to approve City Council Minutes from February 17, 2025. Second by Collins. Motion was approved unanimously by voice vote.

Motion by Campbell to approve Committee of the Whole Minutes from February 17, 2025. Second by Collins. Motion was approved unanimously by voice vote.

Motion by Dockery to approve the bills payable in the amount of \$200,072.73. Second by Campbell. Motion was approved unanimously by voice vote.

Motion by Iossi to approve a Liquor License Renewal for Rustic Ridge Golf Course. Second by Collins. Motion was approved unanimously by voice vote.

Old Business

Motion by Dockery to approve the Second Reading of Ordinance 2025-07 Updating the City Sanitary Sewer Rates. Second by Campbell. Roll call vote indicated Campbell (Aye), Collins (Aye), Dockery (Aye), and Iossi (Aye).

Motion by Campbell to approve Motion to Suspend the Rules and waive the Third Reading as required by Iowa Code Section 380.3 of Ordinance #2025-06 to allow for a vote for final passage. Second by Iossi. Roll call vote indicated Campbell (Aye), Collins (Aye), Dockery (Aye), and Iossi (Aye).

Motion by Iossi to approve the Final Reading of Ordinance 2025-06 Updating Franklin Park to Sanctuary Gardens. Second by Campbell. Roll call vote indicated Campbell (Aye), Collins (Aye), Dockery (Aye), and Iossi (Aye).

Motion by Campbell to approve amended IAQC Transit Study Joint Agreement with the Cities of Bettendorf, Davenport, Eldridge and LeClaire. Second by Collins. Motion was approved unanimously by voice vote.

New Business

Motion by Dockery to approve 2025 Street Closure Request from the Eldridge-North Scott Chamber for the Moonlight Chase and Eldridge Summer Festival event. Second by Campbell. Motion was approved unanimously by voice vote.

Motion by lossi to approve the First Reading of Ordinance 2025-05 Shared Use Paths. Second by Collins Roll call vote indicated Campbell (Aye), Collins (Aye), Dockery (Aye), and lossi (Aye).

Motion by Campbell to approve the First Reading of Ordinance 2025-08 Updating Deduct Meter Policy. Second by Collins. Roll call vote indicated Campbell (Aye), Collins (Aye), Dockery (Aye), and lossi (Aye).

Motion by lossi to approve Resolution 2025-07 Approving the Planned Residential Overlay Development Plan for Grunwald Grove 2nd Addition . Second by Dockery. Roll call vote indicated Campbell (Aye), Collins (Aye), Dockery (Aye), and lossi (Aye).

Board/Staff Activity Reports

City Administrator – Sewer Master Plan kick-off meeting took place February 21st and once a timeline is known Council will be updated. The City's new website project is moving along well, a first draft for staff will hopefully be available next week. Sometime soon a meeting will be scheduled for Mayor and Council headshots and bios. The equipment sale on Purple Wave closed on February 18th with the winning bid for the Public Works pick-up truck coming in at \$9,100. A meeting was held with the Rotary regarding the band-shell project. Rotary has raised about half for the project and are working the Army Core of Engineers on next steps. Follow up regarding the Wetland Delineation Report and for someone to present would be an additional cost of \$120 an hour. A good relationship has been established pertaining the report and a presentation does not seem necessary. As a result of the traffic study done for South 1st Street, there is a recommendation for two speed track signs. The recently awarded bid for South 1st Street did not include those items. The signs are about \$11,000 each. Council can discuss and decide soon. A memorial bench for not only parks but perhaps other areas is also something Council can discuss and will be added as an agenda item.

Assistant City Administrator – 5 ft sidewalks are becoming the norm for most cities in the area. To be in line with other area cities and the desire from the public for sidewalks to be wider, City staff and City engineer recommend this be considered for Eldridge and information and initial plans can be brought to the Council as an agenda item.

City Clerk – The ERP Pro 10 software conversion for the City's financial and utility functions is ongoing. The City is recognizing even in this early stage some of the new functions and features will be a great tool for staff.

Police Chief – Not present.

Motion by Dockery to adjourn the meeting at 7:50pm. Second by Iossi Motion was approved unanimously by voice vote.

Frank King
Mayor

Letty Goslowsky
City Clerk/Finance Manager

City of Eldridge City Committee of the Whole Meeting Minutes

The City of Eldridge, Iowa, City Council met in an open Committee of the Whole session at the Eldridge Community Center at 6:00 pm on March 3, 2025.

Council Members Present: Scott Campbell, Dan Collins, Brian Dockery and Ryan Iossi.
Adiran Blackwell was not present.

Presiding: Mayor Frank King

Also Present: Nevada Lemke, Jeff Martens, Letty Goslowsky, Marty O'Boyle, Dale Grunwald, Josh Haycraft, Scott LaPlant, Karsyn Alan, Kalan Gromet and Erin Gentz

Motion by Iossi to approve the agenda. Second by Collins. Motion approved by unanimous voice vote.

New Business

Assistant City Administrator Jeff Martens asked about non-profit signage and if the Council would like to consider adding a provision in the code to either allow or not allow non-profit signage. Council agreed it should be something to consider and requested Jeff to work with other city departments to prepare some guidelines to bring to Council to possibly amend the current code.

The Building Inspector Ray Nees presented his budget requests and provided clarification when asked.

Old Business

Discussions continued regarding the FY Tax Levy and the FY 2026 Budget for the City of Eldridge. City Administrator Nevada Lemke provided an updated budget draft and a wage increase impact table. Nevada also advised the Tax Levy is due on March 5th 2025 and Council would need to make a decision in the current meeting on what percentage the Council wanted to submit. Discussion was had and Council advised Nevada to submit 8.11%.

The FY2026 Budget on-going discussion then commenced. Funding for public facilities and the volunteer fire were had, as well as what future projects, staffing and needs the City wants for future growth and maintenance. Pros and cons were evaluated and discussed.

Throughout the COW meeting the Council asked various financial questions, clarification and answers were provided by both the City Administrator and Assistant City Administrator Jeff Martens.

Motion by Dockery to adjourn at 6:58pm. Second by Iossi. Motion was approved unanimously by voice vote.

Respectfully Submitted by Letty Goslowsky, Finance Manager/City Clerk

BILLS PAYABLE

CHECK#	DEPT	FUND	VENDOR	DESCRIPTION	AMOUNT
1164	POLICE	001 5-110-6150	EBS - EMPLOYEE BENEFIT SYST	ADMIN FEES	\$ 97.88
1164	INSPECTION	001 5-170-6150	EBS - EMPLOYEE BENEFIT SYST	ADMIN FEES	\$ 9.62
1164	STREET	001 5-210-6150	EBS - EMPLOYEE BENEFIT SYST	ADMIN FEES	\$ 68.34
1164	VEHICLE	001 5-299-6150	EBS - EMPLOYEE BENEFIT SYST	ADMIN FEES	\$ 10.13
1164	VEHICLE	001 5-599-6150	EBS - EMPLOYEE BENEFIT SYST	ADMIN FEES	\$ 20.25
1164	ADMIN	001 5-611-6150	EBS - EMPLOYEE BENEFIT SYST	ADMIN FEES	\$ 14.18
1164	FINANCE	001 5-620-6150	EBS - EMPLOYEE BENEFIT SYST	ADMIN FEES	\$ 16.18
1164	SEWER	610 5-815-6150	EBS - EMPLOYEE BENEFIT SYST	ADMIN FEES	\$ 51.10
1165	ADMIN	820 5-001-6183	EBS - EMPLOYEE BENEFIT SYST	PSF CLAIM FUNDING	\$ 2,979.41
155581	ADMIN	001 5-640-6411	AHLERS & COONEY P.C.	ELDRIDGE GENERAL URP	\$ 342.00
155584	SANITATION	001 5-290-6497	ALLIED SERVICES LLC	GARBAGE/RECYCLE SERVICES	\$ 34,856.64
155585	POLICE	001 5-110-6599	ALWAYS CLEAN LLC	CLEANING SERVICES	\$ 300.00
155585	STREET	001 5-210-6310	ALWAYS CLEAN LLC	CLEANING SERVICES	\$ 300.00
155585	ADMIN	001 5-611-6310	ALWAYS CLEAN LLC	CLEANING SERVICES	\$ 300.00
155586	POLICE	001 5-110-6181	AMAZON CAPITAL SERVICES	EARPIECE HEADSET	\$ 17.82
155586	POLICE	001 5-110-6506	AMAZON CAPITAL SERVICES	FINGERPRINT INK	\$ 18.02
155586	POLICE	001 5-110-6599	AMAZON CAPITAL SERVICES	CAR CLEANING SUPPLIES	\$ 33.98
155586	POLICE	001 5-110-6727	AMAZON CAPITAL SERVICES	CROSSWALK STOP SIGN	\$ 17.49
155586	ADMIN	001 5-620-6506	AMAZON CAPITAL SERVICES	WIRELESS HEADSET	\$ 46.99
155587	POLICE	001 5-110-6331	BURT ACQUISITIONS LLC	POLICE FLEET	\$ 84.00
155590	SALES TAX	121 5-750-6752	DOORS INC	DOOR LOCK SYSTEM	\$ 1,670.00
155591	FINANCE	001 5-620-6414	EASTERN IOWA PUBLICATION LLC	CITY PUBLISHING	\$ 997.85
155592	ADMIN	001 5-611-6601	ELDRIDGE LUMBERYARD CO.	WALL CABINETS	\$ 836.05
155593	VEHICLE	001 5-299-63322	ELDRIDGE WELDING	FLAT FOR TRUCK 24	\$ 45.00
155594	POLICE	001 5-110-6470	HUMANE SOCIETY OF	TRIP/BOARDING FEES	\$ 150.00
155595	POLICE	008 5-110-6350	IOWA DEPT. OF JUSTICE	PROPERTY SEIZED	\$ 1,340.72
155596	POLICE	001 5-110-6480	IOWA LAW ENFORCEMENT ACADEMY	2 MPI TRANSFER	\$ 40.00
155596	POLICE	001 5-110-6480	IOWA LAW ENFORCEMENT ACADEMY	EVALUATION	\$ 150.00
155597	ADMIN	001 5-611-6407	ISG I&S GROUP INC.	CITY HALL/PD PREPLANNING	\$ 3,957.50
155598	ADMIN	001 5-299-6504	LAWSON PRODUCTS INC.	WIRES	\$ 199.68
155599	VEHICLE	001 5-299-63322	MIDWEST WHEEL	QUAD MOUNT	\$ 60.64
155600	VEHICLE	001 5-299-63322	MILLS CHEVROLET	HOSE	\$ 230.80
155601	VEHICLE	001 5-299-6332	NAPA AUTO PARTS	OIL FILTER	\$ 8.44
155601	VEHICLE	001 5-299-63322	NAPA AUTO PARTS	ENGINE/AIR FILTER	\$ 89.65
155601	VEHICLE	001 5-299-6504	NAPA AUTO PARTS	SEAM SEALER	\$ 30.27
155602	VEHICLE	001 5-299-63323	NOTT COMPANY	NOSE PIECE/COUPLER	\$ 398.70
155603	VEHICLE	001 5-299-63322	P & K MIDWEST INC	JOHN DEERE WIDE AREA MOWER	\$ 159.82
155606	POLICE	001 5-110-6331	RADAR ROAD TEC	RADAR CERTS	\$ 318.00
155608	POLICE	001 5-110-6250	RELENTLESS LLC DBA DESERT SNOW	3 DAY CRIMINAL WORKSHOP	\$ 699.00
155609	POLICE	001 5-110-6506	RNJS DISTRIBUTION INC.	WATER	\$ 12.00
155609	FINANCE	001 5-620-6506	RNJS DISTRIBUTION INC.	WATER	\$ 12.00
155610	POLICE	008 5-110-6350	SCOTT COUNTY ATTORNEY'S OFFICE	PROPERTY SEIZED	\$ 3,351.81
155611	POLICE	001 5-110-6319	SHARED IT INC	IT SERVICES	\$ 599.35
155611	STREET	001 5-210-6373	SHARED IT INC	IT SERVICES	\$ 236.88
155611	FINANCE	001 5-620-6373	SHARED IT INC	IT SERVICES	\$ 314.40
155611	SEWER	610 5-815-6373	SHARED IT INC	IT SERVICES	\$ 159.35
155612	VEHICLE	001 5-299-63323	TITAN MACHINERY	PUSHER	\$ 120.00
155613	SALES TAX	121 5-750-6730	TREETOP PRODUCTS CONSOLIDATED	POST ASPHALT/CONCRETE MOUNT	\$ 2,301.96
155615	ST LIGHTS	001 5-230-6371	ALLIANT ENERGY CO.	STREET LIGHTS	\$ 416.94
155615	ST LIGHTS	001 5-230-6371	ALLIANT ENERGY CO.	STREET LIGHTS	\$ 25.99
155615	SEWER	610 5-815-6371	ALLIANT ENERGY CO.	IND PARK LIFT STATION	\$ 221.60
ACH	SPLIT	SPIT	PAYROLL 3/14	PAYROLL 3/14	\$94,765.37
				TOTAL:	\$ 153,503.80

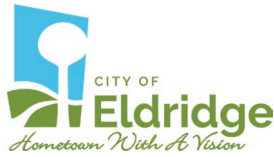

ORDINANCE 2025-07

AN ORDINANCE REPEALING SECTIONS OF TITLE C, CHAPTER TWO OF THE ELDRIDGE CITY CODE, AND ADOPTING NEW SECTIONS 3.00 AND 3.01 ESTABLISHING NEW SEWER RATES, REPEALING ALL ORDINANCES AND RESOLUTIONS IN CONFLICT WITH THIS ORDINANCE AND PROVIDING FOR AN EFFECTIVE DATE.

Section One. The portions of Section 3.00, Chapter Two, Title C, are hereby repealed and the following new language for Section 3.00 is hereby adopted.

3.00 Residential rates. Sewer rates for all single residential properties including property owned by any religious organization and used as a church, synagogue, or other place of worship, shall be based upon average water consumption as billed in the months of January February and March according to the schedule below. A single residential property is defined as a single-family home, an individual townhouse or row house, an apartment within a larger building, a mobile home or any grouping of rental rooms using a common bathroom. All residential users shall be charged the same rate regardless of the location where wastewater is treated.

<u>Rate</u>	<u>Usage</u>
\$0.91/100 gallons	0 to 90,000 gallons
\$0.79/100 gallons	Over 90,000 gallons
\$40.55	Minimum billing

The bill, as determined by the average consumption described above, shall become effective with the April 1st billing of each year, and remain in effect until April 1st of the following year. Prior to April 1st of each year, average consumption shall be recalculated to determine if the residential customer's bill should be adjusted. Properties connected to sewer, but without metered water consumption, shall be subject to the minimum billing amount.

Section Two. The portions of Section 3.01, Chapter Two, Title C, of the Eldridge City Code are repealed and the following portion of Section 3.01 is hereby adopted.

3.01 Commercial and Industrial Rates. Sewer Rates for non-residential users, including schools, shall be based upon monthly water consumption. All nonresidential rates shall be charged the same rate regardless of the location wastewater is treated.

<u>Rate</u>	<u>Usage</u>
\$0.91/100 gallons	0 to 90,000 gallons
\$0.79/100 gallons	Over 90,000 gallons
\$40.55	Minimum billing

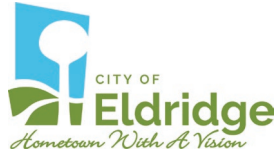

Section three. Repealer. All ordinances, resolutions, and parts of ordinances and resolutions in conflict with this ordinance are hereby repealed.

Section four. Effective date. This ordinance shall take effect upon its passage and publication as provided by law and become effective on April 1st, 2025.

PASSED AND APPROVED THIS 24TH DAY OF MARCH, 2025.

Attest:

Mayor, Frank King

Leticia Goslowsky, City Clerk

Blackwell	<input type="checkbox"/> Yea / <input type="checkbox"/> Nay / <input type="checkbox"/> _____
Campbell	<input type="checkbox"/> Yea / <input type="checkbox"/> Nay / <input type="checkbox"/> _____
Collins	<input type="checkbox"/> Yea / <input type="checkbox"/> Nay / <input type="checkbox"/> _____
Dockery	<input type="checkbox"/> Yea / <input type="checkbox"/> Nay / <input type="checkbox"/> _____
Iossi	<input type="checkbox"/> Yea / <input type="checkbox"/> Nay / <input type="checkbox"/> _____

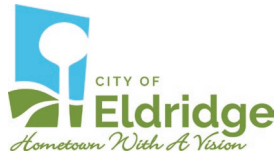

ORDINANCE 2025-05

SHARED USE PATHS

AN ORDINANCE AMENDING TITLE B PUBLIC ORDER, CHAPTER ONE TRAFFIC, OF THE ELDRIDGE CITY CODE, REPEALING ALL ORDINANCES IN CONFLICT WITH THIS ORDINANCE AND PROVIDING FOR AN EFFECTIVE DATE.

Section 1.00. Section 4.08 Bicycle Paths, Chapter One Traffic, Title B Public Order of the Eldridge City Code is amended by removing the following language.

§ 4.08 BICYCLE PATHS.

It shall be unlawful to operate a motorized vehicle, including, but not limited to, cars, trucks, snowmobiles, all-terrain vehicles (ATVs) and motorized scooters upon designated bicycle paths. This prohibition shall not apply to motorized wheelchairs, emergency response vehicles and city-owned maintenance vehicles.

Section 2.00. Section 4.08 Bicycle Paths, Chapter One Traffic, Title B Public Order of the Eldridge City Code is amended by adding the following language.

§ 4.08 SHARED USE PATHS.

It shall be unlawful to operate a motorized vehicle, including, but not limited to, cars, trucks, snowmobiles, all-terrain vehicles (ATVs) and motorized scooters upon designated Shared Use Paths as defined in City Code. This prohibition shall not apply to motorized wheelchairs, emergency response vehicles and city-owned maintenance vehicles.

Section 3.00. Section 6.00 Snow Emergency, Section 6.08 Bicycle Paths, Chapter One Traffic, Title B Public Order of the Eldridge City Code is amended by removing the following language.

§ 6.08 BICYCLE PATHS.

It shall be the responsibility of the city to promptly remove snow and/or ice from designated bicycle paths around the city.

Section 4.00. Section 6.00 Snow Emergency, Section 6.08 Bicycle Paths, Chapter One Traffic, Title B Public Order of the Eldridge City Code is amended by adding the following language.

§ 6.08 SHARED USE PATHS.

Shared Use Paths are closed from December 1 through March 15 or when accumulation of snow, ice or water exists on the surface of the trail.

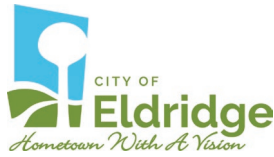

Section 5.00. Section 10 Shared Use Paths, Chapter One Traffic, Title B Public Order of the Eldridge City Code is added with the following language.

§ 10.00 SHARED USE PATHS.

§ 10.01 PURPOSE.

The purpose of this section is to define Shared Use Paths and establish when they are closed for maintenance.

§ 10.02 DEFINITION.

SHARED USE PATH. A multi-use trail that's physically separated from motorized traffic. Shared Use Paths can be used by pedestrians, bicyclists, and other non-motorized users.

§ 10.03 MAINTENANCE.

A Shared Use Path will be closed when debris exists on the surface of the trail that needs to be cleared by the Public Works Department, during maintenance or repairs, or at other times such as the trail may be closed by the order of the Public Works Director.

Section 6.00. All ordinances, or parts of ordinances, in conflict with this ordinance are hereby repealed.

Section 7.00. This ordinance shall take effect upon passage and publication according to law. Passed and approved this 7th day of April 2025.

Attest:

Mayor, Frank King

Leticia Goslowsky, City Clerk

Blackwell	<input type="checkbox"/> Yea	/	<input type="checkbox"/> Nay	/	<input type="checkbox"/> _____
Campbell	<input type="checkbox"/> Yea	/	<input type="checkbox"/> Nay	/	<input type="checkbox"/> _____
Collins	<input type="checkbox"/> Yea	/	<input type="checkbox"/> Nay	/	<input type="checkbox"/> _____
Dockery	<input type="checkbox"/> Yea	/	<input type="checkbox"/> Nay	/	<input type="checkbox"/> _____
Iossi	<input type="checkbox"/> Yea	/	<input type="checkbox"/> Nay	/	<input type="checkbox"/> _____

Mayor Frank King
Councilman Adrian Blackwell

Councilman Scott Campbell
Councilman Daniel Collins

Councilman Ryan Iossi
Councilman Brian Dockery

City of Eldridge

MEMORANDIUM

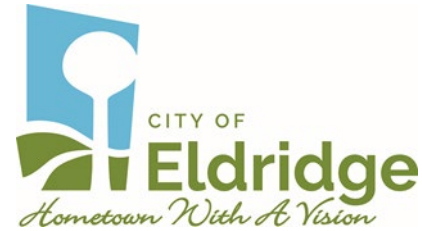

To: Mayor and City Council
From: Jeff Martens, Assistant City Administrator
Re: Deduct Meter Ordinance Update
Date: 3/3/25

Mayor and City Council,

The City Utility Billing System is set up to bill sewer customers a rate that is based on the amount of water they purchase.

There are users of water, mostly in industrial areas, that purchase water that does not enter the city sewer system because it is used for production of a product or some other use.

Our current ordinances do not specifically address this issue. This ordinance update puts a formal system in place to fairly accommodate these users.

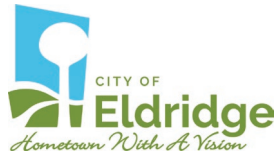

ORDINANCE 2025-08

DEDUCT METER POLICY

AN ORDINANCE AMENDING TITLE C PUBLIC WORKS, CHAPTER TWO SEWER RATES, SECTION 3.01 COMMERCIAL AND INDUSTRIAL RATES OF THE ELDRIDGE CITY CODE, REPEALING ALL ORDINANCES IN CONFLICT WITH THIS ORDINANCE AND PROVIDING FOR AN EFFECTIVE DATE.

Section 1.00. Section 3.01, Chapter Two, Title C of the Eldridge City Code is amended by removing the following language.

§ 3.01 COMMERCIAL AND INDUSTRIAL RATES.

Sewer rates for non-residential users, including schools, shall be based upon monthly water consumption. All non-residential rates shall be charged the same rate regardless of the location wastewater is treated.

Rate	Usage
\$0.91/100 gallons	0 to 90,000 gallons
\$0.79/100 gallons	Over 90,000 gallons
\$40.55	Minimum billing

Section 2.00. Section 3.01, Chapter Two, Title C of the Eldridge City Code is amended by adding the following language.

§ 3.01 COMMERCIAL AND INDUSTRIAL RATES.

- (A) Sewer rates for non-residential users, including schools, shall be based upon monthly water consumption. All non-residential rates shall be charged the same rate regardless of the location where wastewater is treated.
- (B) A non-residential user may be using water for production, or other purposes, that results in water purchased not entering the City sewer system. At their option and expense, they can install a separate deduct meter system approved by both the sewer and water superintendents to monitor this consumption.

Rate	Usage
\$0.91/100 gallons	0 to 90,000 gallons
\$0.79/100 gallons	Over 90,000 gallons
\$40.55	Minimum billing

Section 3.00. All ordinances, or parts of ordinances, in conflict with this ordinance are hereby repealed.

Mayor Frank King
Councilman Adrian Blackwell

Councilman Scott Campbell
Councilman Daniel Collins

Councilman Ryan Iossi
Councilman Brian Dockery

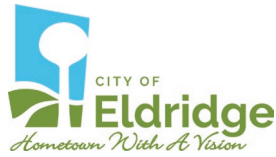

Section 4.00. This ordinance shall take effect upon passage and publication according to law. Passed and approved this 7th day of April 2025.

Attest:

Mayor, Frank King

Leticia Goslowski, City Clerk

Blackwell	<input type="checkbox"/> Yea / <input type="checkbox"/> Nay / <input type="checkbox"/> _____
Campbell	<input type="checkbox"/> Yea / <input type="checkbox"/> Nay / <input type="checkbox"/> _____
Collins	<input type="checkbox"/> Yea / <input type="checkbox"/> Nay / <input type="checkbox"/> _____
Dockery	<input type="checkbox"/> Yea / <input type="checkbox"/> Nay / <input type="checkbox"/> _____
Iossi	<input type="checkbox"/> Yea / <input type="checkbox"/> Nay / <input type="checkbox"/> _____

City of Eldridge

MEMORANDIUM

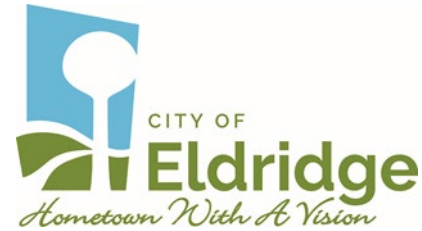

To: Mayor and City Council
From: Jeff Martens, Assistant City Administrator
Re: Sidewalk Ordinance Amendment
Date: 3/17/25

Mayor and City Council,

In order to better provide for pedestrian traffic, and to align our City sidewalk requirements with those of Bettendorf and Davenport, City Staff and the City Engineer are requesting that you consider the following ordinance amendment that changes sidewalk widths in new development from 4' wide to 5' wide.

Existing blocks will be able to construct and reconstruct at the previous 4' width and setbacks but all new developments would be required to construct 5' wide sidewalks going forward.

The Building Official will provide guidance in transition areas between old and new developments to ensure continuity throughout the City.

While updating the sidewalk language in City Code the following code sections should also be updated as they contain old language that was never enforced:

(6) The driveway approach from the edge of the street ~~slab~~ to the right-of-way line shall be constructed of PCC concrete with a ~~five~~ ~~four~~-foot wide sidewalk delineated through the approach. The Zoning Administrator or City Engineer, or their designee, prior to construction, shall approve the proposed approach width, location, radii and overall design. ~~All existing driveways with a rock surface shall have PCC concrete approaches constructed by no later than December 31, 2002;~~

~~(7) All existing driveways and parking areas located between the property line and the building setback line, which do not currently meet the all weather surface requirements, shall be brought into compliance by no later than December 31, 2009;~~

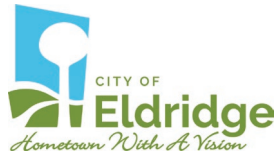

ORDINANCE 2025-09

AN ORDINANCE AMENDING CITY CODE TO REQUIRE A 5' SIDEWALK IN NEW DEVELOPMENTS AND REMOVING UNENFORCED REFERENCES TO CONCRETE APPROACHES AND ALL WEATHER SURFACES, REPEALING ALL ORDINANCES IN CONFLICT WITH THIS ORDINANCE AND PROVIDING FOR AN EFFECTIVE DATE.

Section 1.00. Section 8.00, Chapter Two, Title C of the Eldridge City Code is amended by removing the following language:

§ 8.00 PUBLIC SIDEWALKS.

See standard drawing for detailed information on sidewalks.

Section 2.00. Section 8.00, Chapter Two, Title C of the Eldridge City Code is amended by adding the following language:

§ 8.00 PUBLIC SIDEWALKS.

- (A) See standard drawing for detailed information on sidewalks.
- (B) All sidewalks shall be constructed a minimum of five feet (5') in width, except that sidewalks constructed or reconstructed in blocks with existing sidewalks shall be of the same width and of the same distance from the property line as the existing sidewalks, as determined by the Building Official.
- (C) Subbase: For all Sidewalks, Shared Use Paths and Driveways, place and compact a minimum 3" subbase material which complies with Iowa DOT Gradation 11 unless otherwise specified in the contract documents or approved by City Engineer.

Section 3.00. Section 35.03, Chapter Two, Title D of the Eldridge City Code is amended by removing the following language.

(6) The driveway approach from the edge of the street slab to the right-of-way line shall be constructed of PCC concrete with a four-foot wide sidewalk delineated through the approach. The Zoning Administrator or City Engineer, or their designee, prior to construction, shall approve the proposed approach width, location, radii and overall design. All existing driveways with a rock surface shall have PCC concrete approaches constructed by no later than December 31, 2002;

(7) All existing driveways and parking areas located between the property line and the building setback line, which do not currently meet the all weather surface requirements, shall be brought into compliance by no later than December 31, 2009;

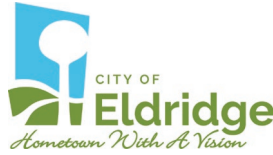

Section 4.00. Section 8.00, Chapter Two, Title C of the Eldridge City Code is amended by adding the following language:

(6) The driveway approach from the edge of the street to the right-of-way line shall be constructed of PCC concrete with a five-foot wide sidewalk delineated through the approach. The Zoning Administrator or City Engineer, or their designee, prior to construction, shall approve the proposed approach width, location, radii and overall design.

(7) [REMOVE THIS LINE AND RENUMBER 8 & 9 TO 7 & 8]

Section 5.00. The attached detail sheets shall replace SD-1, SD-2, SD-28 and SD-30 in the City Details.

Section 6.00. All ordinances, or parts of ordinances, in conflict with this ordinance are hereby repealed.

Section 7.00. This ordinance shall take effect upon passage and publication according to law. Passed and approved this 21st day of April 2025.

Attest:

Mayor, Frank King

Leticia Goslowski, City Clerk

Blackwell	<input type="checkbox"/> Yea	/	<input type="checkbox"/> Nay	/	<input type="checkbox"/> _____
Campbell	<input type="checkbox"/> Yea	/	<input type="checkbox"/> Nay	/	<input type="checkbox"/> _____
Collins	<input type="checkbox"/> Yea	/	<input type="checkbox"/> Nay	/	<input type="checkbox"/> _____
Dockery	<input type="checkbox"/> Yea	/	<input type="checkbox"/> Nay	/	<input type="checkbox"/> _____
Iossi	<input type="checkbox"/> Yea	/	<input type="checkbox"/> Nay	/	<input type="checkbox"/> _____

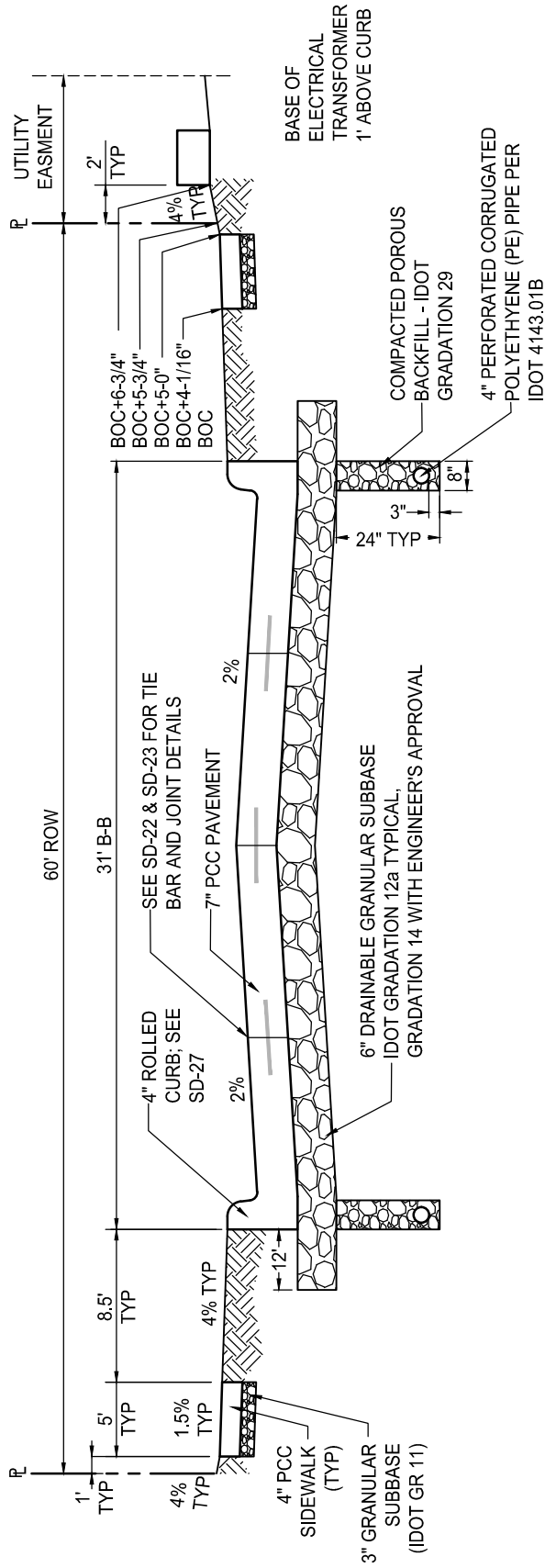

GENERAL NOTES:

1. MAXIMUM OUTLET DISTANCE FOR SUBDRAIN PIPE SHALL BE 500'.
2. PROVIDE TRANSVERSE SUBDRAIN PIPE AT LOW POINTS IN ROADWAY PROFILE. TRANSVERSE PIPE PROFILE TO MATCH ROADWAY CROSS SECTION SO AS TO DRAIN INTO LONGITUDINAL SUBDRAIN PIPE OR INTAKES.
3. COMPACTED SUBGRADE UNDER PAVING SHALL EXTEND TO A MINIMUM OF 12 INCHES BEYOND THE PAVEMENT BACK OF CURB.
4. SUBDRAIN PIPE NOT IN CONFLICT WITH STORM SEWER MAY BE INSTALLED WITH THE OUTER TRENCH FACE EVEN WITH THE BACK OF CURB TO 12 INCHES INSIDE THE BACK OF CURB. SUBDRAIN PIPE IN CONFLICT WITH STORM SEWER SHALL BE INSTALLED BETWEEN THE STORM SEWER AND THE STREET CENTERLINE, WITH THE OUTER SUBDRAIN TRENCH FACE 10 INCHES FROM THE OUTER WALL OF THE PIPE.

CITY OF
ELDRIDGE

Detail Description:

TYPICAL SECTION - 31' STREET

Date:

2/27/25

Detail Number:

SD-1

CITY OF
ELDRIDGE

Detail Description:

UTILITY LOCATION AND BACKFILL DETAIL

Date:

2/27/25

Detail Number:

SD-2

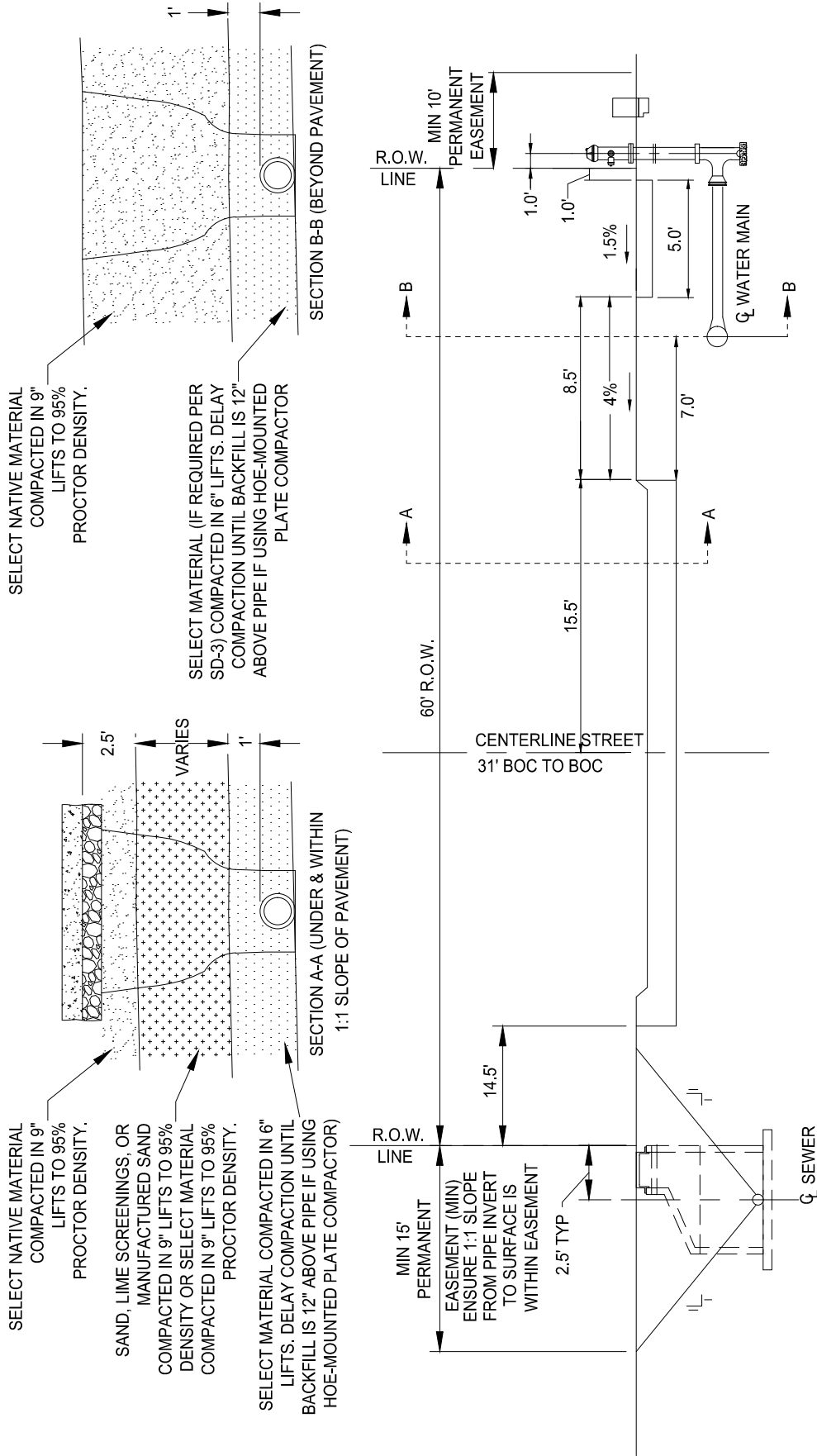

NOTES:

1. DISTURBED MATERIAL IN THE EXCAVATION MUST BE COMPACTED TO 95% DENSITY
2. SELECT MATERIAL PLACED IN TRENCH UNDER PAVING SHALL BE INCLUDED IN THE PIPE INSTALLATION COST. NO ADDITIONAL PAYMENT WILL BE MADE FOR SELECT BACKFILL UNDER EXISTING OR PROPOSED PAVING.
3. MANHOLE COVERS SHALL BE SET TO FINAL SIDEWALK GRADE. IF FURTHER ADJUSTMENT IS NECESSARY BECAUSE OF FUTURE LOT GRADING IT SHALL BE THE RESPONSIBILITY OF THE PROPERTY OWNER.
4. BACKFILL FOR PIPE TRENCH EXCAVATION UNDER PAVING SHALL CONFORM TO THAT SHOWN IN SECTION C-C ABOVE AND AS SPECIFIED IN CHAPTER 10 PARAGRAPH 1.15 OF THE STANDARD SPECIFICATIONS.
5. THE PLANTING OF TREES OR SHRUBS IN THE RIGHT-OF-WAY OR OR PERMANENT EASEMENT SHALL BE PROHIBITED.
6. INSIDE OF MANHOLE CASTING SHALL BE LOCATED AT PROPERTY LINE/R.O.W. LINE.

STANDARD CURB PROFILE, MATCH STREET CURB HEIGHT (4" OR 6");
 TAPER FROM FULL HEIGHT CURB AT STREET TO NO HEIGHT CURB AT CONNECTING SIDEWALK, MAINTAIN 6" WIDTH REGARDLESS OF HEIGHT

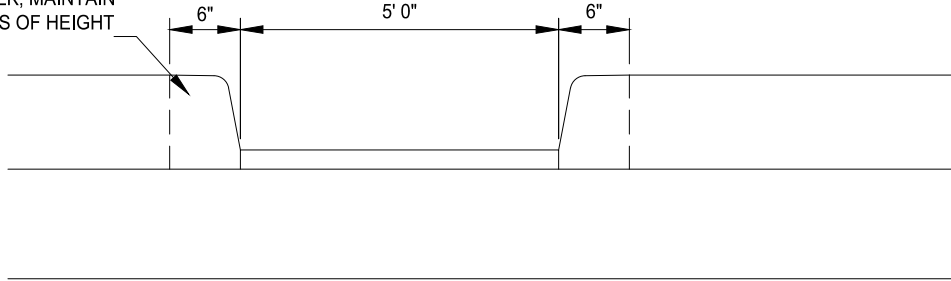

RAMP ELEVATIONS

(N.T.S.)

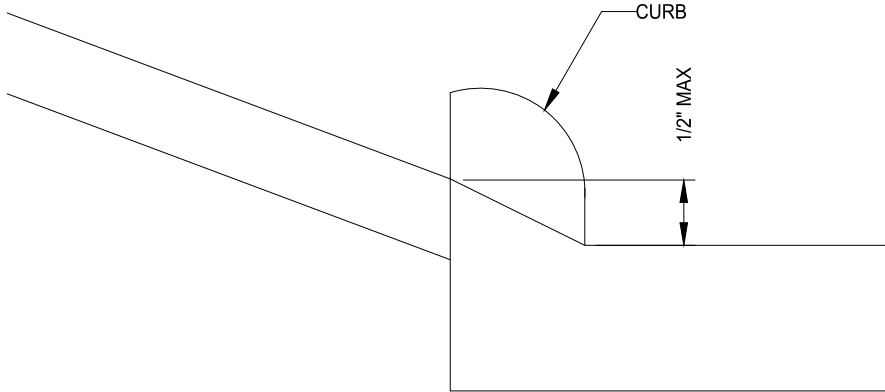

RAMP SECTION

(N.T.S.)

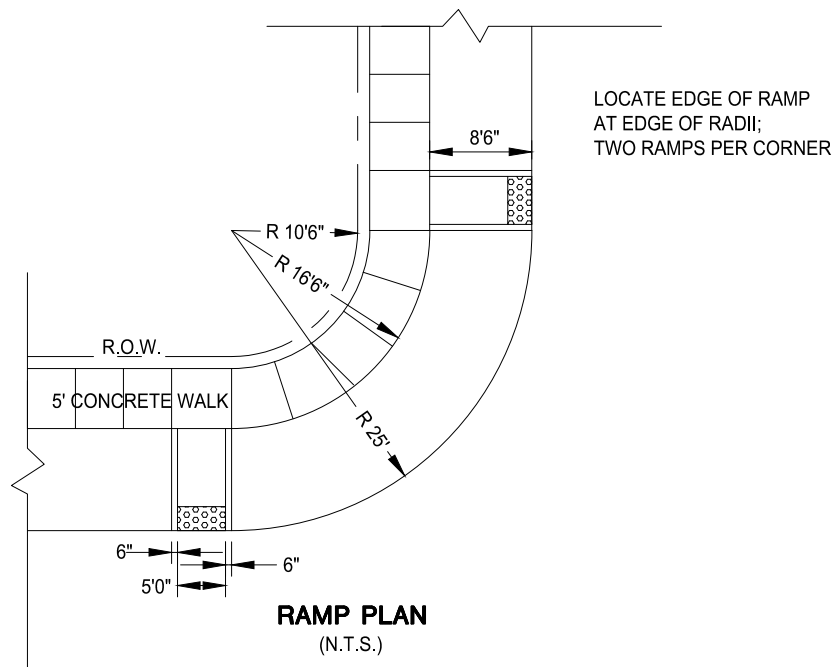

RAMP PLAN

(N.T.S.)

NOTE:

RAMP CONSTRUCTION SHALL MEET ADA & PROWAG REQUIREMENTS.

*CITY OF
ELDRIDGE*

Detail Description:

STREET - SIDEWALK DETAIL

Date:

2/27/25

Detail Number:

SD-28

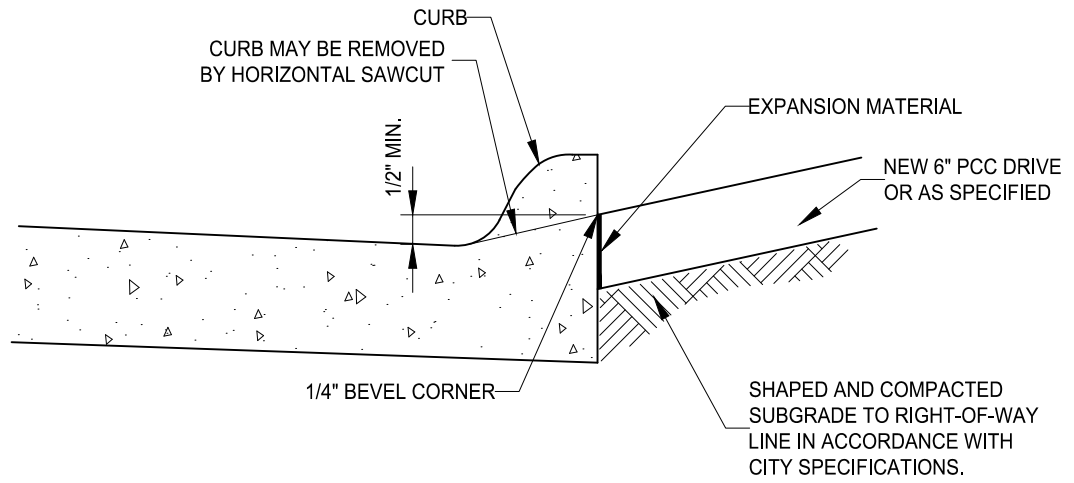

CONTRACTION JOINTS EVERY 4' - 5', 1/2" EXPANSION JOINTS EVERY 100' AND WHERE ABUTTING EXISTING PAVEMENT

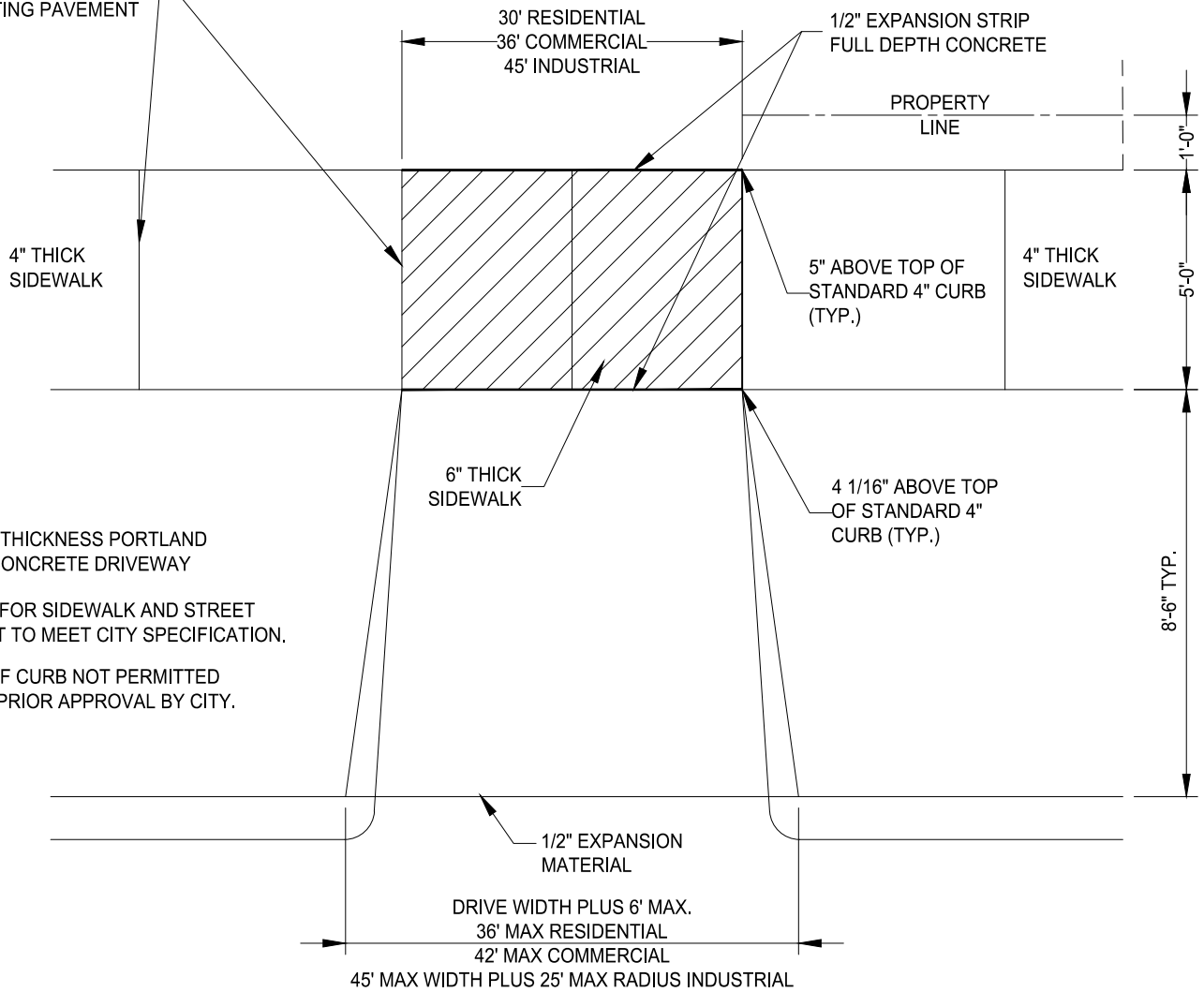

NOTES:

1. 6" MINIMUM THICKNESS PORTLAND CEMENT CONCRETE DRIVEWAY
2. CONCRETE FOR SIDEWALK AND STREET PAVEMENT TO MEET CITY SPECIFICATION.
3. REMOVAL OF CURB NOT PERMITTED WITHOUT PRIOR APPROVAL BY CITY.

*CITY OF
ELDRIDGE*

Detail Description:

**RESIDENTIAL AND COMMERCIAL
(FLARED) DRIVEWAY**

Date:

2/27/25

Detail Number:

SD-30

Precision Concepts
 Precision Concepts
 305 E. Kimberly Road
 Davenport, IA 52806 US
 +15634241787
 service@precision-concepts.com
 www.precision-concepts.com



Estimate

ADDRESS
 City of Eldridge
 305 N 3rd St
 Eldridge, IA 52748

ESTIMATE #	DATE
1855	01/09/2025

STOCK NUMBER
 City Hall

ACTIVITY	QTY	RATE	AMOUNT
House:TINT002 26x20x55 In Reflective Mirror	198.61	10.00	1,986.10T
House:TINT002 1x20x35 In Reflective Mirror	4.86	10.00	48.60T
House:TINT002 2x18x38 In Reflective Mirror	9.50	10.00	95.00T
			Subtotal: 2,129.70
House:Clear002 3x32x28 In Retention Film	18.66	12.00	223.92T
House:Clear002 2x30x32	13.33	12.00	159.96T
House:Clear002 2x29x26	10.47	12.00	125.64T
			Subtotal: 509.52
House:Clear002 Entry Restriction anchoring (takes the retention film and makes it much more difficult to gain entry.) Couple things to consider. "Mirrored" or reflective tint will require the outside area of the glass to be brighter than the internal area you are protecting. It requires the light to create the "mirror effect". I can bring samples by for your consideration and show you what I mean. Weather will play a factor in installation time. We would not want to install tint if temperatures are going to be below 20 degrees for a couple nights after the application. Please let me know if you have any questions and if you would like me to bring by some samples for your consideration. -John Boosalis 563.723.1718	69	3.50	241.50T

Thank you for choosing Precision Concepts for your Car Accessory and Electronics Needs. Estimates are good for 30 Days from the original date. Please let us know if you have any questions. We look forward to serving you.
Sincerely,
Precision Concepts

SUBTOTAL	2,880.72
TAX	201.65
TOTAL	\$3,082.37

Accepted By

Accepted Date

SHATTERGUARD

QTY	MEASUREMENTS	SQ FT	TOTAL SQ FT	COST
26	20" X 55"	7.64	198.64	\$3,970.81
1	20" X 35"	4.86	4.86	\$97.15
2	18" X 38"	4.75	9.5	\$189.91
3	32" X 28"	6.22	18.66	\$335.69
2	30" X 32"	6.67	13.34	\$239.99
2	29" X 26"	5.24	10.48	\$188.54

TOTAL \$5,022.09

Jordan @ globalsecurityexperts.com

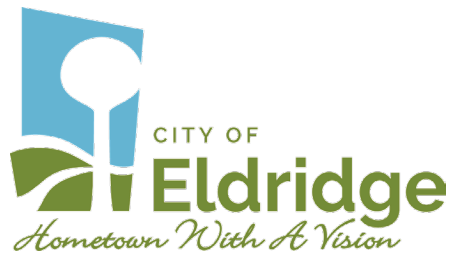

RESOLUTION 2025-09

A RESOLUTION APPROVING INTERFUND TRANSFERS

NOW THEREFORE BE IT RESOLVED by the City Council of the City of Eldridge, Iowa that the city staff is authorized to make the following transfers between funds:

- | | |
|---------------|-----------------------------------------------|
| A. \$ 65,000 | General Fund to Park Board |
| B. \$20,000 | General Fund to General Equipment Replacement |
| C. \$ 120,000 | General Fund to Self-Insurance |
| D. \$ 16,000 | Sales Tax to Community Center |
| E. \$ 25,000 | Sales Tax to Street Projects |
| F. \$ 100,000 | Sales Tax to Park Improvements |
| G. \$ 258,000 | Sales Tax to Debt Service |
| H. \$ 192,671 | Sales Tax to General Fund |
| I. \$ 20,000 | Hotel / Motel to Community Center |
| J. \$ 645,010 | United TIF Area to Debt Service |
| K. \$ 279,671 | United TIF Area to Sales Tax |
| L. \$ 90,000 | Sewer Fund to Sewer Equipment Replacement |
| M. \$ 50,000 | Sewer Fund to Insurance Self-Funding |
| N. \$ 184,190 | Sewer Fund to Debt Service |

PASSED AND APPROVED THIS 24TH DAY OF MARCH 2025.

Attest:

Mayor, Frank King

City Clerk, Letty Goslowsky

Blackwell Yea Nay Absent

Campbell Yea Nay Absent

Collins Yea Nay Absent

Dockery Yea Nay Absent

Iossi Yea Nay Absent

City of Eldridge

ACTIVITY REPORT

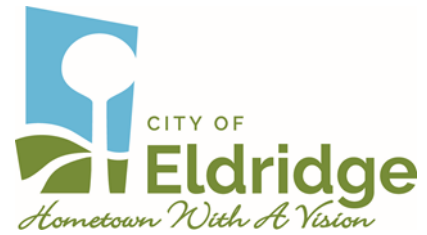

To: Mayor & City Council
From: Tony Rupe
Re: Public Works Activity Report
Date: 3/11/25

Mayor and Council

Crews are trimming trees at all city facilities and properties

Crews are filling potholes

Park cleanup will begin this month

Two employees are currently testing to obtain pesticide licenses

We have contacted Eastern Iowa Paving and have requested two weeks' notice before they return to work on N 7th Street and N 8th Street to complete the 2024 street restoration project

Plowing for 24/25 is likely complete. Plowing hours were lower this year compared to an average year. Salt usage was slightly over normal due to repetitive early morning ice events / slick road conditions

Bollards will be installed this week on the new Townsend Farms trail due to multiple passenger vehicles mistaking the path for a street

The new digester blowers were installed last week at the wastewater treatment plant. Electrical work and control work is remaining

Crews assisted the Community Center by installing the retrofit LED recessed lighting

The regular meeting of the Board of Trustees of the Eldridge Electric and Water Utility Board was called to order at 5:00 p.m. on March 4, 2025, at Eldridge City Hall.

The board members present were Michael Bristley, Mark Goodding, Racheal Padavich, and Jeff Hamilton. Abby Petersen was present via telephone. Also present were Cegan Long, Collin Wilson, Marty O'Boyle, Ryan Iossi, Nevada Lemke, and Sadie Wagner.

Public Comment – none.

Motion by Padavich to approve Agenda. Second by Goodding. All Ayes. Motion Carries.

Motion by Hamilton to approve Utility Board Minutes from February 18, 2025. Second by Goodding. All Ayes. Motion Carries.

Financial & Administrative-

- A. Motion by Padavich to Approve Bills Payable in the amount of \$231,879.50. Second by Hamilton. All Ayes. Motion Carries.
- B. Motion by Padavich to approve FY26 Budget for the Water and Electric Utility Funds. Second by Petersen. All Ayes. Motion Carries.
- C. Department Update – Given by Utility Administrative Manager Sadie Wagner. Wagner has enrolled in an Online College course, Electric Utilities Fundamentals and Future. She recently attended the 2025 IAMU Energy Conference. Also, she attended a business visit to LMT with Assistant City Administrator Jeff Martens and QC Chamber's Chris Graves as part of her training program.

Electric Department

- A. Outages – none.
- B. Motion by Goodding to approve Resolution 2025-07 E&W Approving a Professional Services Agreement with Stanley Consultants. Second by Padavich. Roll Call Vote Was Taken. Bristley (Aye), Petersen (Aye), Padavich (Aye), Hamilton (Aye), Goodding (Aye). Motion Carries.
- C. Department update – Given by Line Foreman Collin Wilson, the line between South 3rd Street and South 3rd Place, off of West Sheridan Dr, is completely rebuilt with new poles. The team has gotten a jump on IUB corrections that had been found in the current inspection. Dalton Eagle and Devin Gheer are currently at a transformer class that goes through 3/6.

Water Department

- A. Water Main Breaks – none.
- B. Water Test Results – Bac-T passed, and fluoride is at a standard level.
- C. Motion by Padavich to approve Resolution 2025-05 E&W Backflow & Prevention Testing Policy. Second by Hamilton. Roll Call Vote Was Taken Petersen (Aye), Goodding (Aye), Hamilton (Aye), Padavich (Aye), Bristley (Aye). Motion Carries.
- D. Department Update – Given by Water Superintendent Cegan Long. The new water operator completed his Grade 1 and is approved for his Grade 2s. Altorfer was out to take coolant samples and scan the generators. Long stated that the reports from previous years showed the same ongoing issues. Jack from Shared IT installed a long-range wireless access point, giving the operators more inner access into the filter room. They have seen an increase in new meter installs and swaps that may cause an increase in the influx of inventory orders. The new meter reading software order process has been initiated for July 1. Unit 301 has been outfitted for the water department.

16th Ave Water Tower Reconditioning Project Bid

- A. Motion by Padavich to Open Public Hearing for the consideration of approval of plans, specifications, form of contract, and estimated total cost of 16th Avenue Water Tower Reconditioning project bid. Second by Goodding. Roll Call Vote Was Taken. Goodding (Aye), Hamilton (Aye), Padavich (Aye), Petersen (Aye), Bristley (Aye). Motion Carries.
- B. Motion by Padavich to Close Public Hearing for the consideration of approval of plans, specifications, form of contract, and estimated total cost of 16th Avenue Water Tower Reconditioning project bid. Second by Goodding. Roll Call Vote Was Taken. Padavich (Aye), Goodding (Aye), Bristley (Aye), Petersen (Aye), Hamilton (Aye). Motion Carries.
- C. Motion by Padavich to approve Resolution 2025-06 E&W Awarding a Contract for the 16th Avenue Water Tower Reconditioning Project. Second by Hamilton. Roll Call Vote Was Taken. Petersen (Aye), Bristley (Aye), Padavich (Aye), Hamilton (Aye), Goodding (Aye). Motion Carries.

Motion by Padavich to adjourn the meeting at 5:31 p.m. Second by Goodding. All Ayes. Motion Carries.

Sadie Wagner

Utility Administrative Manager

BILLS PAYABLE

CHECK #	DEPT	FUND	VENDOR	DESCRIPTION	FREQUENCY	AMOUNT
1151	ELECTRIC	630 5-820-6503	CENTRAL MUNICIPAL POWER	ENERGY SUPPLY	MONTHLY	\$ 169,663.90
226591	DEP REFUND	630 2033	HENDRIKSEN JORDAN	01-6077-18	AS NEEDED	\$ 89.93
226592	DEP REFUND	630 2033	MC GEE KYLE	03-1540-05	AS NEEDED	\$ 103.69
226593	DEP REFUND	630 2033	GERSTMAR AMANDA	07-0551-06	AS NEEDED	\$ 1.87
226594	ELECTRIC	630 5-820-6310	A & A AIR COND & REFRIGERATION INC	ICE MACHINE RENT	MONTHLY	\$ 62.50
226595	ELECTRIC	630 5-820-6340	ACCESS SYSTEMS LEASING	COPIER LEASE	MONTHLY	\$ 120.77
226596	WATER	600 5-810-6310	ACCO UNLIMITED CORP.	VENTING CAUSTIC TANK MATERIALS	PROJECT BASED	\$ 1,394.00
226597	WATER	600 5-810-6310	ALLMAKES OFFICE FURNITURE	DESK FOR UTILITY ADMIN MANAGER	ONE TIME	\$ 984.36
226597	ELECTRIC	630 5-820-6310	ALLMAKES OFFICE FURNITURE	DESK FOR UTILITY ADMIN MANAGER	ONE TIME	\$ 984.36
226598	ELECTRIC	600 5-810-6310	AMAZON CAPITAL SERVICES	LABEL MAKER	AS NEEDED	\$ 194.40
226598	ELECTRIC	630 5-820-6240	AMAZON CAPITAL SERVICES	CC IAMU-2IAMU TRAINING	ONE TIME	\$ 1,000.00
226598	ELECTRIC	630 5-820-6310	AMAZON CAPITAL SERVICES	LABEL MAKER	AS NEEDED	\$ 194.41
226598	ELECTRIC	630 5-820-6506	AMAZON CAPITAL SERVICES	PORTFOLIO FOLDER	AS NEEDED	\$ 11.90
226598	ELECTRIC	630 5-820-65061	AMAZON CAPITAL SERVICES	HEADSET	AS NEEDED	\$ 70.91
226598	ELECTRIC	635 5-820-6710	AMAZON CAPITAL SERVICES	CC LIND FORD-RNG BRDS ELEC TRK	AS NEEDED	\$ 648.72
226599	WATER	600 5-810-6240	CEGAN LONG	IA RURAL WATER CONF MILEGE/GAS	ONE TIME	\$ 290.01
226600	WATER	600 5-810-6373	CENTRAL SCOTT TELEPHONE	PHONE AND INTERNET	MONTHLY	\$ 10.00
226600	ELECTRIC	630 5-820-6373	CENTRAL SCOTT TELEPHONE	PHONE AND INTERNET	MONTHLY	\$ 10.00
226601	ELECTRIC	630 5-820-6310	CINTAS CORPORATION	FLOOR MATS	MONTHLY	\$ 82.62
226601	ELECTRIC	630 5-820-6310	CINTAS CORPORATION	FLOOR MATS	MONTHLY	\$ 53.98
226602	WATER	600 5-810-6310	CLIMATE ENGINEERS-QC	HVAC MAINTENANCE	AS NEEDED	\$ 1,510.00
226602	WATER	600 5-810-6310	CLIMATE ENGINEERS-QC	HVAC SERVICE	AS NEEDED	\$ 150.75
226602	WATER	600 5-810-6310	CLIMATE ENGINEERS-QC	HVAC SERVICE	AS NEEDED	\$ 150.75
226603	ELECTRIC	630 5-820-64131	COMMUNITY ACTION OF EASTERN IOWA	PROJECT SHARE	MONTHLY	\$ 54.00
226604	ELECTRIC	630 5-820-6605	DE NOVO MARKETING	WEBSITE REDEVELOPMENT/CONTENT	PROJECT BASED	\$ 4,166.50
226605	WATER	600 5-810-6310	DULTMEIER SALES	AIRLINE FITTINGS	AS NEEDED	\$ 302.85
226606	ELECTRIC	630 5-820-6332	FREEDOM HYDRAULICS INC	SEAL KITS/RESEAL 3 CYLINDERS	AS NEEDED	\$ 731.23
226607	WATER	600 5-810-6501	HAWKINS INC.	CHLORINE CYLINDERS	AS NEEDED	\$ 1,619.73
226608	WATER	600 5-810-6407	ISG I&S GROUP INC.	ENGINEERING	AS NEEDED	\$ 4,992.50
226609	WATER	600 5-810-6213	JOHNSON CONTROLS SECURITY SOLUTIONS	SECURITY MAINTENANCE FEE	MONTHLY	\$ 485.17
226610	WATER	600 5-810-6310	MENARDS	AIRLINE FITTINGS RETURN	RETURN	\$ (13.72)
226610	WATER	600 5-810-6310	MENARDS	AIRLINE FITTINGS	AS NEEDED	\$ 51.68
226610	WATER	600 5-810-6310	MENARDS	AIRLINE FITTINGS	AS NEEDED	\$ 17.96
226610	WATER	600 5-810-6310	MENARDS	GARBAGE BAGS/AIRLINE FITTINGS	AS NEEDED	\$ 33.92
226610	WATER	600 5-810-6506	MENARDS	TISSUES	AS NEEDED	\$ 11.58
226610	WATER	600 5-810-6506	MENARDS	GARBAGE BAGS/AIRLINE FITTINGS	AS NEEDED	\$ 38.98
226610	ELECTRIC	630 5-820-6310	MENARDS	POLY DUMP CART	ONE TIME	\$ 249.00
226611	WATER	600 5-810-6371	MIDAMERICAN ENERGY COMPANY	401 S 16TH AVE GENERATOR	MONTHLY	\$ 16.47
226611	WATER	600 5-810-6371	MIDAMERICAN ENERGY COMPANY	853 N 1ST GENERATOR	MONTHLY	\$ 34.82
226611	WATER	600 5-810-6371	MIDAMERICAN ENERGY COMPANY	851N 1ST ST WELL 5	MONTHLY	\$ 100.41
226611	WATER	600 5-810-6371	MIDAMERICAN ENERGY COMPANY	503 W DONAHUE ST	MONTHLY	\$ 84.64
226611	WATER	600 5-810-6371	MIDAMERICAN ENERGY COMPANY	212 N 3RD ST	MONTHLY	\$ 74.34
226611	ELECTRIC	630 5-820-6371	MIDAMERICAN ENERGY COMPANY	120 E IOWA ST	MONTHLY	\$ 442.48
226612	ELECTRIC	630 5-820-6332	NAPA AUTO PARTS	AIR FILTER	AS NEEDED	\$ 41.94
226613	ELECTRIC	630 5-820-6416	NERC	NERC/MRO REGION ASSESSMENT	QUARTERLY	\$ 761.16
226614	WATER	600 5-810-6373	QUAD CITIES TAS	QUAD CITIES TAS	MONTHLY	\$ 30.53
226614	ELECTRIC	630 5-820-6450	QUAD CITIES TAS	QUAD CITIES TAS	MONTHLY	\$ 30.53
226615	ELECTRIC	630 5-820-6507	RESCO	CROSSARMS	AS NEEDED	\$ 986.62
226616	ELECTRIC	630 5-820-6332	TEREX GLOBAL GMBH	CYLINDER	AS NEEDED	\$ 893.65
226617	ELECTRIC	630 5-820-6508	U.S. POST OFFICE	POSTAGE	MONTHLY	\$ 1,078.37
226618	WATER	600 5-810-6371	USA BLUE BOOK	TESTING SUPPLIES	AS NEEDED	\$ 200.89
226619	WATER	600 5-810-6560	VAN WERT INC	WATER METERS	AS NEEDED	\$ 3,880.18
226620	WATER	600 5-810-6373	VERIZON WIRELESS	UTILITY CELLULAR	MONTHLY	\$ 185.25
226620	ELECTRIC	630 5-820-6373	VERIZON WIRELESS	UTILITY CELLULAR	MONTHLY	\$ 166.51
226621	WATER	600 5-810-6331	WEX BANK	FUEL	MONTHLY	\$ 338.25
226621	ELECTRIC	630 5-820-6331	WEX BANK	FUEL	MONTHLY	\$ 433.89
ACH	SPLIT	SPLIT	PAYROLL 3/1	PAYROLL 3/1	BI-WEEKLY	\$ 28,429.87
				TOTAL:		\$ 228,736.01

CREDIT CARDS

DEPT	EMPLOYEE	FUND	VENDOR	DESCRIPTION	AMOUNT
1152	CEGAN LONG	600 5-810-6181	MUCH BOOT COMPANY	NEW OPERATOR-PPE	\$ 133.75
1152	CEGAN LONG	600 5-810-6181	HOME DEPOT	PPE	\$ 123.88
1152	TANNER LOUSSAERT	600 5-810-6213	IA DNR	WATER CERT TEST FEES	\$ 32.29
1152	TANNER LOUSSAERT	600 5-810-6230	IAMU	TRENCHING/SHORING WKSHOP	\$ 182.00
1152	BRYSON STYMEIST	600 5-810-6230	IAMU	TRENCHING/SHORING WKSHOP	\$ 182.00
1152	CEGAN LONG	600 5-810-63711	HOME DEPOT	TRUCK TOOLS	\$ 793.85
1152	CEGAN LONG	600 5-810-63711	FARM & FLEET	BACKWASH HOSE NOZZLES	\$ 110.97
1152	CEGAN LONG	600 5-810-63711	HOME DEPOT	HANDHELD VACUUM & HAMMER	\$ 158.97
1152	CEGAN LONG	600 5-810-63711	FARM & FLEET	WT PLANT TOOLS	\$ 374.93
1152	JEFFREY MARTENS	600 5-810-63711	UI.COM	ACCESS POINT U6 LONG RANGE WTP	\$ 200.74
1152	JEFFREY MARTENS	600 5-810-6373	UI.COM	SWITCH 24 POE FOR WTP	\$ 412.74

1152	COLLIN WILSON	630 5-820-6240	HOLIDAY INN	LODGING IAMU CONF	\$ 355.25
1152	DEVIN GHEER	630 5-820-6457	COMMERCIAL PRINTERS	SHIPPING GLOVES AND SLEEVES	\$ 65.00
1152	DALTON EAGLE	630 5-820-6504	DOLLAR GENERAL	RUGS FOR CITY SHOP	\$ 17.12
CREDIT CARDS					\$ 3,143.49
BILLS PAYABLE					\$ 228,736.01
GRAND TOTAL					\$ 231,879.50